

**Class X Session 2024-25**  
**Subject - Science**  
**Sample Question Paper - 1**

**Time Allowed: 3 hours**

**Maximum Marks: 80**

**General Instructions:**

1. This question paper consists of 39 questions in 5 sections.
2. All questions are compulsory. However, an internal choice is provided in some questions. A student is expected to attempt only one of these questions.
3. Section A consists of 20 objective-type questions carrying 1 mark each.
4. Section B consists of 6 Very Short questions carrying 02 marks each. Answers to these questions should be in the range of 30 to 50 words.
5. Section C consists of 7 Short Answer type questions carrying 03 marks each. Answers to these questions should be in the range of 50 to 80 words.
6. Section D consists of 3 Long Answer type questions carrying 05 marks each. Answers to these questions should be in the range of 80 to 120 words.
7. Section E consists of 3 source-based/case-based units of assessment of 04 marks each with sub-parts.

**Section A**

1. Which characteristic is observed by the reaction shown in the given image? [1]

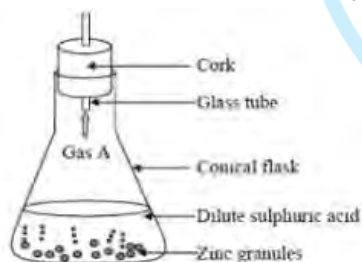

- |                               |                                                    |  |
|-------------------------------|----------------------------------------------------|--|
| a) Formation of a precipitate | b) Change in temperature                           |  |
| c) Evolution of a gas         | d) Both change in temperature and evolution of gas |  |
2.  $\text{BaCl}_2 + \text{Na}_2\text{SO}_4 \rightarrow \text{BaSO}_4 + 2\text{NaCl}$ . It is type of: [1]
- |                                                                 |                                 |
|-----------------------------------------------------------------|---------------------------------|
| a) Both Precipitation reaction and Double displacement reaction | b) Double displacement reaction |
| c) Decomposition reaction                                       | d) Precipitation reaction       |
3. Acid present in tomato is: [1]
- |                |                   |
|----------------|-------------------|
| a) Acetic acid | b) Methanoic acid |
|----------------|-------------------|

c) Lactic acid

d) Oxalic acid

4. Which of the following are called soft soaps? [1]

a) Potassium salts

b) Calcium salts

c) Magnesium salts

d) Sodium salts

5. Take three boiling tubes A, B and C. Pour some water in test tube A Put iron nails in it and cork it. Pour boiled distilled water in another test tube B and put iron nails in it. Add 1 ml of oil over it such that oil floats over it and prevents the air from entering. Take some iron nails in test tube C and put some anhydrous calcium chloride in it and cork it. [1]

Leave all the three test tubes for one day and then observe.

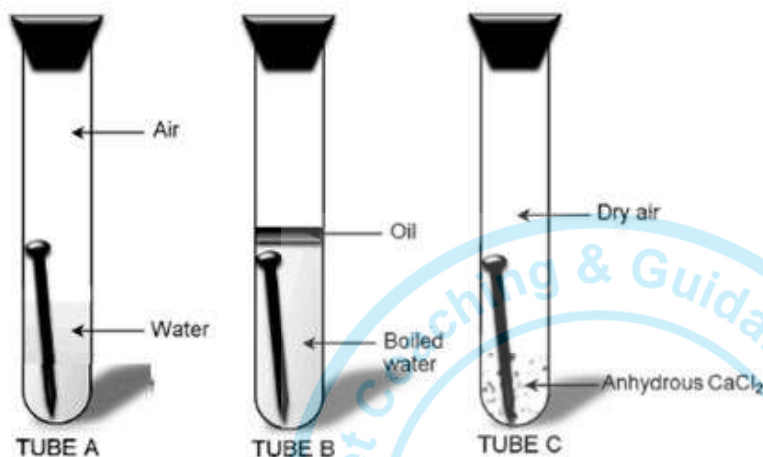

In which test tube nail is rusted?

a) Tube B and C

b) Tube B

c) Tube A

d) Tube A and C

6. Which oxide will turn blue litmus solution to red? [1]

A. SO<sub>2</sub>

B. MgO

C. Na<sub>2</sub>O

D. NO<sub>2</sub>

a) A and D

b) B and C

c) A and C

d) All of these

7. Butanone is a four carbon compound with the functional group: [1]

a) - COOH

b) - CHO

c) - CO -

d) - OH

8. In the excretory system of human beings, some substances in the initial filtrate such as glucose, amino acids, salts and water are selectively reabsorbed in [1]

a) Ureter

b) Urethra

c) Urinary bladder

d) Nephron

9. The genotype for the height of an organism is Tt. What conclusion may be drawn from this? [1]



- a) Both A and R are true and R is the correct explanation of A.                      b) Both A and R are true but R is not the correct explanation of A.
- c) A is true but R is false.                      d) A is false but R is true.

18. **Assertion (A):** Vaginal pills contain spermicides. [1]  
**Reason (R):** Spermicides kill the sperms.

- a) Both A and R are true and R is the correct explanation of A.                      b) Both A and R are true but R is not the correct explanation of A.
- c) A is true but R is false.                      d) A is false but R is true.

19. **Assertion (A):** The magnetic field intensity at the centre of a circular coil carrying current changes, if the current through the coil is doubled. [1]  
**Reason (R):** The magnetic field intensity is dependent on current in conductor.

- a) Both A and R are true and R is the correct explanation of A.                      b) Both A and R are true but R is not the correct explanation of A.
- c) A is true but R is false.                      d) A is false but R is true.

20. **Assertion (A):** In an ecosystem, the function of producers is to convert organic compounds into inorganic compounds. [1]  
**Reason (R):** Green plants, the producers, transduce solar energy.

- a) Both A and R are true and R is the correct explanation of A.                      b) Both A and R are true but R is not the correct explanation of A.
- c) A is true but R is false.                      d) A is false but R is true.

**Section B**

21. Why does micelle formation take place when soap is added to water? Will a micelle be formed in other solvents such as ethanol also. [2]
22. Define the term pollination. Differentiate between self-pollination and cross-pollination. What is the significance of pollination? [2]
23. What are the components of the transport system in highly organized plants? [2]

OR

What are the two phases of photosynthesis reactions?

24. A concave lens has a focal length of 10 cm. An object 2.5 cm high is placed 30 cm from the lens. Determine the position and size of the image. [2]
25. Give some examples along with reasons of insecticides that are banned due to their fatal effects. [2]

OR

What is ozone and how does it affect any ecosystem?

26. What type of lens we wear if we are suffering from myopia ? [2]

**Section C**

27. Nikita took Zn, Al, Cu, Fe, Mg and Na metal and put each metal in cold water and then hot water. She reacted the metal with steam [3]
- (i) Name the metal which reacts with cold water.
- (ii) Which of the above metals react with steam?



- (iii) Name the metal which reacts with hot water.  
 (iv) Arrange these metals in order of increasing reactivity.
28. Name a metal/non-metal: [3]
- Which makes iron hard and strong?
  - Which is alloyed with any other metal to make an amalgam?
  - Which is used to galvanize iron articles?
  - Whose articles when exposed to air form a black coating?

OR

Give reasons:

- Platinum, gold and silver are used to make jewellery.
  - Sodium, potassium and lithium are stored under oil.
  - Aluminium is a highly reactive metal, yet it is used to make utensils for cooking.
  - Carbonate and sulphide ores are usually converted into oxides during the process of extraction.
  - Lemon or tamarind juice are effective in cleaning tarnished copper vessels.
29. Draw the diagram of part of leaf from which transpiration takes place. Explain stomatal or foliar transpiration. [3]
30. In pea plant, round seed is dominant over the wrinkled. If a cross is carried out between these two plants, give answer to the following questions. [3]
- Mention the genes for the traits of parents.
  - State the trait of  $F_1$  hybrids.
  - Write the ratio of  $F_2$  progeny obtained from this cross. What is the name of the cross?
31. What is atmospheric refraction? Explain with the help of a labelled diagram that the position of a star as seen by us is not its true position. [3]
32. a. Calculate the resistance of a metal wire of length 2 m and area of cross-section  $1.55 \times 10^{-6} \text{ m}^2$ . (Resistivity of the metal is  $2.8 \times 10^{-8} \Omega\text{m}$ ) [3]  
 b. Why are alloys preferred over pure metals to make the heating elements of electrical heating devices?
33. i. An electric lamp of 100 ohms, a toaster of resistance 50 ohms and a water filter of resistance 500 ohms are connected in parallel to a 220V source. what is the resistance of the electric iron connected to the same source that takes as much current as all the three appliances and what is the current through it? [3]  
 ii. Which uses more energy, a 250 W TV set for 1 hour or a 1,200 W toaster for 10 minutes?

**Section D**

34. i. Compare soaps and detergents on the basis of their composition and cleansing action in hard water. [5]  
 ii. What happens when ethanol is treated with sodium metal? State the behaviour of ethanol in this reaction.  
 iii. Draw the structure of cyclohexane.  
 iv. Name the following compound.

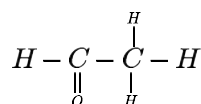

OR

Draw the possible isomers of the compound with molecular formula  $\text{C}_3\text{H}_6\text{O}$  and also give their electron dot structures.

35. Why are budding, fragmentation and regeneration all considered as asexual types of reproduction? With neat [5]

diagrams explain the process of regeneration in Planaria.

OR

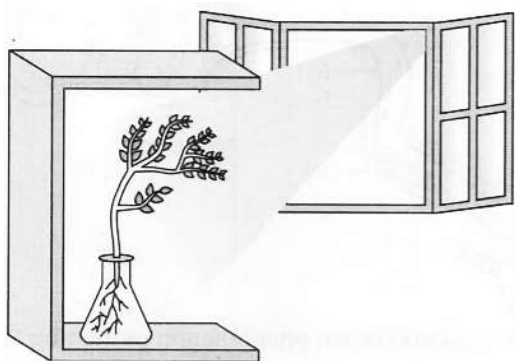

Observe the above figure carefully and answer the following:

- Which phenomenon does the figure represent?
- Which plant hormone is involved?
- How this plant hormone brings this movement?

36. What is lens formula ? Give its sign conventions and assumptions. [5]

OR

Differentiate between a concave mirror and a convex mirror.

#### Section E

37. **Read the text carefully and answer the questions:** [4]

The teacher while conducting practicals in the laboratory divided the students into three groups and gave them various solutions to find out their pH and classify them into acidic, basic and neutral solutions.

Group A - Lemon juice, vinegar, colourless aerated drink

Group B - Tomato juice, coffee, ginger juice

Group C - Sodium hydroxide, sodium chloride, lime water

- For the solutions provided, which group is/are likely to have pH value (i) less than 7, and (ii) greater than 7?
- List two ways of determining pH of a solution.

OR

Explain, why the sour substances such as lemon juice are effective in cleaning the tarnished copper vessels.

38. **Read the text carefully and answer the questions:** [4]

Fill a conical flask with water. Cover the neck of the flask with a wire mesh. keep two or three freshly germinated bean seeds on the wire mesh. Take a cardboard box which is open from one side. Keep the flask a wire mesh. Kin the box in such a manner that the open side of the box faces light coming from a window as shown in the given figure. After two or three days, you will notice that the shoots bend towards light and roots away from light. Now turn the flask so that the shoots are away from light and the roots towards the light. Leave it undisturbed in this condition for a few days. Plants show tropism in response to other stimuli as well. The roots of a plant always grow downwards while the shoots usually grow upwards and away from the earth. This upward and downward growth of shoots and roots, respectively, in response to the pull of earth or gravity, is

obviously, geotropism.



- What has represented by the given activities?
- Do old parts of the shoot and root change direction? Is there any difference in the direction of the new growth?
- What can we conclude from this activity?

OR

What is geotropism?

39. **Read the text carefully and answer the questions:**

[4]

A student was asked to perform an experiment to study the force on a current carrying conductor in a magnetic field. He took a small aluminum rod AB, a strong horse shoe magnet, some connecting wires, a battery and a switch and connected them as shown. He observed that on passing current, the rod gets displaced. On reversing the direction of current, the direction of displacement also gets reversed. On the basis of your understanding of this phenomenon, answer the following questions :

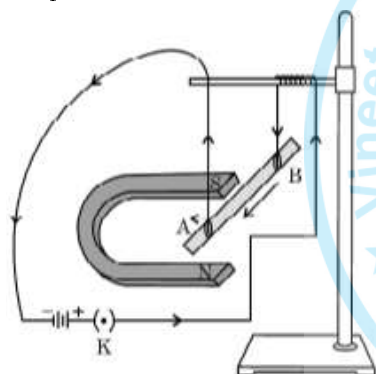

- State the condition under which the displacement of the rod is largest for the same magnitude of current flowing through it.
- State the rule that determines the direction of the force on the conductor AB.
- If the U shaped magnet is held vertically and the aluminum rod is suspended horizontally with its end B towards due north, then on passing current through the rod from B to A as shown, in which direction will the rod be displaced?
  - Name any two devices that use current carrying conductors and magnetic field.

OR

Draw the pattern of magnetic field lines produced around a current-carrying straight conductor held vertically on horizontal cardboard. Indicate the direction of the field lines as well as the direction of the current flowing through the conductor.



**Today is your  
OPPORTUNITY to build the  
TOMORROW you want.**

**ADMISSIONS OPEN**

Session 2024-25

*for*

**AMU XI ENTRANCE**

Science / Diploma / Commerce / Humanities

**Batches Starting Soon**

**Vineet Coaching & Guidance Centre**

VCGC Tower, Phase I, ADA Colony, Ramghat Road, Aligarh-202001 (UP)  
website : [www.vcgc.in](http://www.vcgc.in) | E-Mail : [vcgc.official@gmail.com](mailto:vcgc.official@gmail.com)

**8923803150, 9997447700**



# XI AMU ENTRANCE RESULTS 2023-24



**Aakash Gaur**



**Kanika Garg**



**Riddhima Tomar**



**Tanmay Mudgal**



**Aastha Sharma**



**Ayush Senger**



**Prabhat Singh**



**Anubhav Gupta**



**Akash Basu**



**Shaurya Gangal**



**Abhishek Gaur**



**Rudraksh Chaudhary**



**Aryan Tiwari**



**Pakhi Garg**



**Rashi Singh**



**Ragini Singh**



**Pratishtha Sharma**



**Aaliya Singh**



**Kanika Singh**



**Yashika**



**Manav Kushwaha**



**Saloni Chaudhary**



**Ayushi Dhanger**



**Ayushi Gautam**



**Mugdha Singh**



**Afifa Malik**



**Khushi Varshney**



**Bhoomi Agarwal**



**Sanchi Popli**



**Shubhi Awasthi**



**Prisha Tanwar**



**Khanak**



**Sanyogita**



**Aakashi Sharma**



**Ipshita Upadhyay**



**Yashi Vashishtha**



**Divya Singh**



**Karnika Singh**



**Harshit Chaudhary**



**Vivek Gautam**

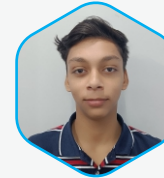

**Lalit Dhanger**



**Prachi Singh**



**Harshit Raghav**



**Srishty**



**Vanshika Garg**



**Aman Varshney**



**Pranjal Tiwari**



**Priyanshi Dhanger**



**Purnank Nandan**

and many more...

 **8923803150, 9997447700**



@vcgc.aligarh



@vcgc\_aligarh



@VCGC Aligarh



VCGC Online



VCGC Online App

# Solution

## Section A

1.

**(d)** Both change in temperature and evolution of gas

**Explanation:** Two observations are made that may suggest that a chemical reaction has taken place in the given image are

- i. evolution of a gas and
- ii. change in temperature.

A pop sound is produced when zinc granules and dilute sulphuric acid reacts together which shows that hydrogen gas is produced during the reaction. The flask also becomes warm showing that there is a change in temperature. Hence, the chemical reaction between zinc and dilute sulphuric acid is characterized by the evolution of hydrogen gas and change in temperature.

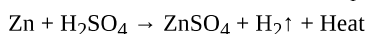

2. **(a)** Both Precipitation reaction and Double displacement reaction

**Explanation:**

- Double decomposition takes place, due to the exchange of ions between the 2 substances. A white precipitate of barium sulphate is formed.
- $\text{BaCl}_2 + \text{Na}_2\text{SO}_4 \rightarrow \text{BaSO}_4 + 2\text{NaCl}$
- $\text{BaSO}_4$  is insoluble in water.  $\text{NaCl}$  dissolves in water.
- $\text{BaSO}_4$  is Barium Sulphate
- $\text{NaCl}$  is common salt of Sodium Chloride

3.

**(d)** Oxalic acid

**Explanation:** More than ten different types of acids, including citric acid, malic acid, ascorbic acid, and oxalic acid, are present in tomatoes. Each 100 g serving of tomatoes contains about 50 mg of oxalic acid. So, the main acid found in tomatoes is oxalic acid.

4. **(a)** Potassium salts

**Explanation:** Potassium salts

5.

**(c)** Tube A

**Explanation:** Iron nails get rusted in test tube A because both air and water are present in it. Iron nails do not get rusted in B because there is water but no air. In C, rusting will not take place because there is neither air nor water.

6. **(a)** A and D

**Explanation:** An acidic oxide will turn blue litmus red. Non-metal oxides (Oxides of S and N) are acidic in nature. Metal oxides (Oxides of Mg and Na) are basic in nature.

7.

**(c)** - CO -

**Explanation:**

Butanone ( $\text{CH}_3\text{COCH}_2\text{CH}_3$ ) is the second member of ketones. It is a four carbon compound with ketone functional group (-CO-). The ketone functional group has two free valencies which are satisfied by one methyl (- $\text{CH}_3$ ) group and one ethyl (- $\text{C}_2\text{H}_5$ ) group.

8.

**(d)** Nephron

**Explanation:** Nephron



9. **(b)** There are at least two different alleles for the gene for height.  
**Explanation:** Genotype is the genetic composition of an organism, i.e., the combination of alleles it possesses. Every character in an organism is controlled by a gene that has at least two alleles that lie on the two homologous chromosomes at the same locus. These alleles may represent the same (homozygous, e.g., TT for height) or alternate expressions (heterozygous, e.g., Tt) of the same character. Thus, if genotype for the height of an organism is Tt, this means there are at least two different alleles for the gene for height, one is T and the other is t.
10. **(a)** Ovulation  
**Explanation:** In general, a woman's fertile window is the day of ovulation (usually 12 to 16 days before the cycle begins) and the five days preceding it.
11. **(b)** Statement (i) is correct.  
**Explanation:** In humans, females have homomorphic sex chromosomes, i.e., two X chromosomes. Thus, they are homogametic, i.e., produce only one type of gametes which contain X chromosomes. Sex chromosomes of human males are heteromorphic or dissimilar, i.e., XY. Human males are therefore heterogametic, i.e., produce two types of gametes.
12. **(b)** All of these  
**Explanation:** Autotrophic nutrition is fulfilled by the process by which autotrophs take in  $\text{CO}_2$  and  $\text{H}_2\text{O}$  and convert these into carbohydrates in the presence of chlorophyll and sunlight. This process is called Photosynthesis.
13. **(d)** 220 v, 50 Hz  
**Explanation:** The voltage in India is 220 volts, alternating at 50 cycles (Hertz) per second. The advantage of 220 is lower current and thus less power loss. And the ability to use thinner wires - less copper.
14. **(a)**  $\frac{1}{25} \Omega$   
**Explanation:** When resistors are connected in parallel, the supply current is equal to the sum of the currents through each resistor. Also, they have the same potential difference across them.  
 In other words, any components in parallel have the same potential difference across them. And, the total resistance will always be lesser than the least resistance in the circuit.  
 The total resistance is calculated as  $\frac{1}{R_T} = \frac{1}{R_1} + \frac{1}{R_2} + \frac{1}{R_3}$ . That is,  $R = R_T^{-1}$   
 In this case, the given resistance is  $\frac{1}{5}$  ohms each. Therefore, the minimum resistance that can be obtained from the parallel connection of these five resistors is given as follows:  
 $\frac{1}{R_T} = \frac{5}{1} + \frac{5}{1} + \frac{5}{1} + \frac{5}{1} + \frac{5}{1} = \frac{25}{1}$ . Therefore,  $R = \frac{1}{25}$   
 Hence, the minimum resistance which can be made using five resistors each of  $\frac{1}{5}$  ohms is  $\frac{1}{25}$  ohms.
15. **(d)** Biomass in a pond ecosystem  
**Explanation:** The pyramid shown here is an inverted pyramid. Pyramid of energy can never be inverted. Number of producers (i.e., phytoplanktons) in a pond are always more than the consumers thus, pyramid of number in a pond cannot be inverted. In a forest, biomass of producers (i.e., tree) is large, so pyramid of biomass in a forest is also upright. Pyramid of biomass for pond ecosystem is inverted as biomass of a trophic level depends on reproductive potential and longevity of its members.
16. **(a)** 5000 KJ  
**Explanation:** According to 10% law, the energy available to each successive trophic level is 10% of the previous trophic level.  
 Given, the energy available at the third trophic level = 50 KJ  
 The energy available at second trophic level =  $50 \text{ KJ} \times 10 = 500 \text{ KJ}$   
 Therefore, the energy available at the producer level (first trophic level) =  $500 \text{ KJ} \times 10 = 5000 \text{ KJ}$
17. **(d)** A is false but R is true.  
**Explanation:** A is false but R is true.
18. **(b)** Both A and R are true but R is not the correct explanation of A.

**Explanation:** Vaginal pills are the chemical methods of birth control. The vaginal pills contain the chemicals called spermicides which kill the sperms.

19. (a) Both A and R are true and R is the correct explanation of A.

**Explanation:** The magnetic field at the centre of circular coil is directly proportional to the current flowing through it. So if current through coil is doubled then magnetic field becomes double.

20. (a) Both A and R are true and R is the correct explanation of A.

**Explanation:** Both A and R are true and R is the correct explanation of A.

### Section B

21. Soaps are sodium or potassium salts of long chain fatty acids. The action of a soap is based on the presence of both hydrophilic and hydrophobic groups in a soap molecule. This action emulsifies the oily dirt and helps in its removal.

The two ends of a soap molecule have different properties. When soap is added to water, the ionic, hydrophilic end of soap molecule dissolves in water. The hydrocarbon chain of soap molecule is hydrophobic and it dissolves in hydrocarbons i.e. links with oily dirt. The hydrocarbon chain of soap molecule orients towards the oil droplet while the ionic end orients towards water (polar solvent). This is how, soap molecules form structures called micelles where the oily dirt is collected in the centre. Thus, soap micelles help in dissolving dirt in water. Micelles stay in solution as colloids and the dirt suspended in the micelles is easily rinsed away.

Micelle formation will not take place in a solvent like ethanol because ethanol will dissolve the hydrocarbon chain of a soap molecule also.

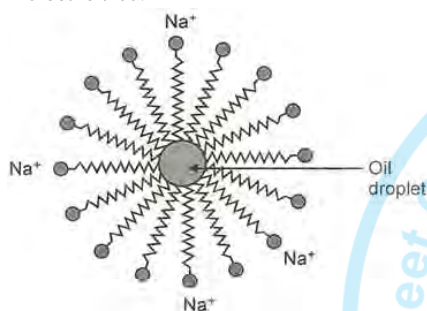

22. Pollination is the act of transferring pollen grains from the male anther of a flower to the female stigma. The goal of every living organism, including plants, is to create offspring for the next generation. One of the ways that plants can produce offspring is by making seeds. Seeds contain the genetic information to produce a new plant.

#### Self-pollination:

- It is the transfer of pollen grains from the anther of the stamen to the stigma of the carpel of the same flower or different flower of the same plant.
- It does not require external agents.
- It does not introduce variation.
- It is a sure and economical method.
- It avoids mixing or dilution of the original characters.
- The progeny becomes weaker after every generation

#### Cross-pollination:

- It is the transfer of pollen grains from the anther to the stigma of different flowers of different plants.
- It requires external agents like wind, insects, etc. to carry out pollination.
- It introduces variation and adaptability.
- It is not economical and is highly wasteful.
- Good characters of a race can be diluted.
- The progeny becomes healthier and better fitted for existence.

23. Components of the transport system in plants

- Xylem tissue – Vessels and tracheoles of roots, stems and leaves are concerned with transport of water and minerals.
- Phloem transports food, amino acid and other substances.

OR

The two phases of photosynthesis reactions are as follows:

- a) Light reaction: In light-dependent reactions, the energy from sunlight is absorbed by chlorophyll and converted into chemical energy in the form of electron carrier molecules like ATP and NADPH. It takes place in the thylakoid of the grana of the

chloroplasts.

b) Dark reaction: In light-independent reactions (Calvin Cycle), carbohydrate molecules are assembled from carbon dioxide using the chemical energy harvested during the light-dependent reactions. It takes place in the stroma of the chloroplasts.

24. Since the lens is concave, hence  $f$  is negative

Given:  $u = -30$  cm;  $f = -10$  cm;  $h = 2.5$  cm;  $v = ?$ ;  $h' = ?$

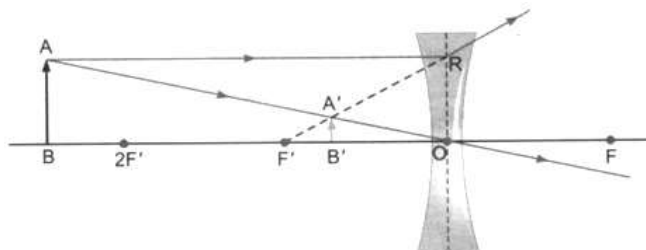

The lens formula for concave lens is  $\frac{1}{v} - \frac{1}{u} = \frac{1}{f}$

$$\frac{1}{v} - \frac{1}{-30} = \frac{1}{-10}$$

$$\frac{1}{v} = \frac{1}{10} - \frac{1}{30}$$

$$\frac{1}{v} = \frac{-3-1}{30}$$

$$v = -7.5 \text{ cm}$$

The negative sign indicates the virtual nature of the image.

The image is at a distance of 7.5 cm from lens (in front of lens).

$$\text{The magnification } m = \frac{v}{u} = \frac{-7.5}{30}$$

$$= \frac{1}{4}$$

$$= +0.25$$

The positive sign with the magnification indicates that the image formed erect.

The size of the image is determined by  $h'$ .

$$\frac{h'}{h} = m$$

$$h' = h \times m$$

$$= 2.5 \times 0.25$$

$$= 0.625 \text{ m}$$

Thus the image formed is virtual and erect. It is at a distance of 7.5 cm from lens and its size is 0.625 cm.

25. Many insecticides such as aldicarb, aldrin, chlorodane and dieldrin with many others have been banned in India due to their harmful effects on life. These pesticides are non-biodegradable and get accumulated in the body of organisms and the concentration of these chemicals increases with each trophic level, thus, killing a large number of organisms and putting various health risks to others.

OR

Ozone is a form of oxygen. It is formed by three atoms of oxygen (Os), whereas normal oxygen molecule is diatomic (O<sub>2</sub>).

Oxygen is essential for all aerobic forms of life and for combustion activities. Ozone, is a deadly poison. Very little of it is present in lower part of the atmosphere called troposphere. In the stratosphere, ozone layer comprises high concentration of ozone some 18-26 km above. Ozone performs an essential function. It shields the surface of the earth from the harmful ultraviolet (UV) radiation of the sun.

26. We rarely use concave lens as is usually supposed. We often use convexo concave lens or any other diverging lens.

### Section C

27. (i) Na

(ii) Al, Zn, Fe

(iii) Mg

(iv) Na > Mg > Al > Zn > Fe > Cu

28. i. Carbon makes iron hard and strong.

ii. Mercury is alloyed with any other metal to make an amalgam.

iii. Zinc used to galvanize iron articles.

iv. Silver article when exposed to air from a black coating.

OR

a. Platinum, gold and silver are used to make jewelry because of their bright shiny surface and high resistance to corrosion. Also they have high malleability and ductility.

- b. Sodium, potassium and lithium are stored under oil to prevent their reaction with oxygen, moisture and carbon dioxide of air so as to protect them.
- c. Aluminum metal forms a thin layer of aluminum oxide all over its surface under the action of moist air. This layer prevents the metal underneath from further corrosion. It is cheap, easily available, malleable and ductile. Therefore, it is used to make utensils for cooking.
- d. It is easier to obtain a metal from its oxides as compared to its sulphides and carbonates. So, prior to reduction, metal carbonate and sulphides must be converted into metal oxides. A carbonate ore is converted into oxide by calcination whereas a sulphide ore is converted into oxide by roasting.
- e. When copper vessels are exposed to moist air, they form a green coating of basic copper carbonate  $[CuCO_3 \cdot Cu(OH)_2]$ .

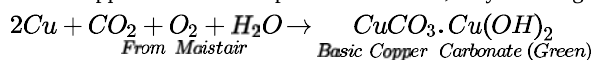

The sour substances such as lemon or tamarind juice contain acids. Lemon juice contains citric acid and tamarind contains tartaric acid. These acids dissolve the coating of copper oxide or basic copper carbonate present on the surface of tarnished copper vessels and make them shining red-brown again.

29. **Stomatal transpiration:** The epidermis has minute pores called stomata. Each stoma is surrounded by two specialised epidermal cells called guard cells. The guard cells are kidney-shaped, possess chloroplasts and less elasticity. Adjacent to the epidermal cells, their walls are thin and elastic. They are thickened near the openings. The stomata remain open in light and close in darkness. Guard cells control the opening or closing of stomata. The stomata form the chief pathway of transpiration. Though the relative total area of the stomatal pore is 1-2% of the total area of the leaf, more transpiration takes place through these stomata only.

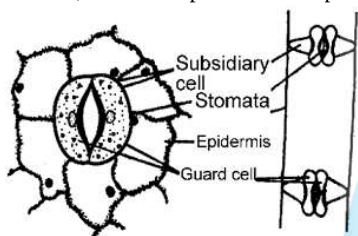

30. i. RR for homozygous pure round. And rr for homozygous pure wrinkle pea plant.  
 ii. Rr (hybrid) - heterozygous. All are round since round is dominant over wrinkled.  
 iii. 3:1 (phenotypic ratio), 1:2:1 (genotypic ratio) The name of this cross is monohybrid cross.
31. **Atmospheric refraction:-** The refraction of light caused by the earth's atmosphere (having their layers of varying optical densities) is called atmospheric refraction. Light from a star is refracted as it leaves space and enters the earth's atmosphere. Air higher up in the sky is rare but that near the Earth's surface is denser. So, as the light from a star comes down the dense air bends the light more. Therefore, the apparent position to the star is slightly different from its actual position.

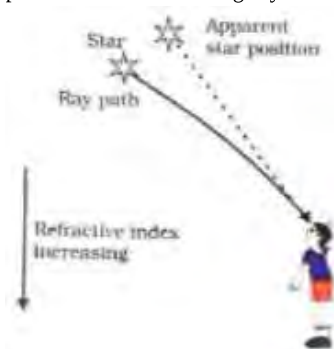

32. a. **Step 1:** Given that:  
 Length( $l$ ) of the metal wire = 2m  
 Area of cross section ( $A$ ) =  $1.55 \times 10^{-6} m^2$   
 Resistivity( $\rho$ ) of the metal =  $2.8 \times 10^{-8} \Omega \cdot m$   
**Step 2:** Calculation of resistance:  
 Resistance of a conductor is given by:  
 $R = \frac{\rho l}{A}$





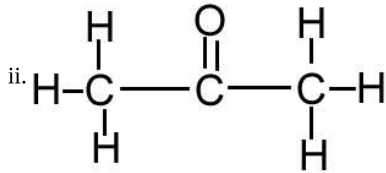

**Prop - 2 - one**

electron dot structure:

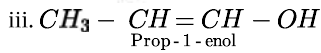
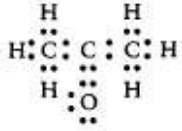

electron dot structure:

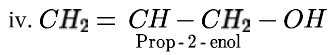
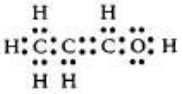

electron dot structure:

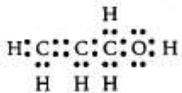

35. Budding, fragmentation and regeneration are all example of asexual reproduction because all of them involve only one parent. Male and female gametes are not involved in the reproduction. Thus in all of the three process no variation is produced. Planaria can be cut into any number of pieces and each piece grows into a complete organism. This process is known as regeneration (see fig.) Regeneration is carried out by specialised cells known as neoblast ( adult stem cells ). These cells proliferate and produce large numbers of cells. From this mass of cells, different cells undergo changes to become various cell types and tissues, giving rise to whole new organism with same DNA content as its parent. These changes take place in an organised manner referred to as development.

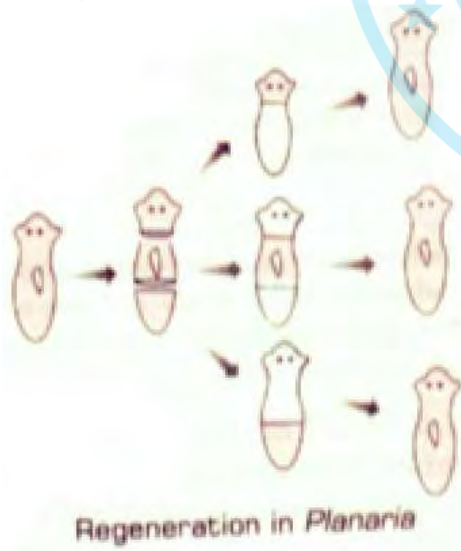

OR

- i. The figure represents the phenomenon of phototropism i.e., response of plants to light.
- ii. The plant hormone auxin is involved in the phenomenon of phototropism.
- iii. Plants show their growth towards light and this movement is caused by the action of auxin hormone. Auxin is synthesised by the meristematic tissue which is present at the tip of shoot, roots etc. In the above figure the plant bends towards the light. Auxin hormone is synthesised in the tip of the stem and moves towards the side of the plant not receiving light. Due to more



auxin hormone in the region of the plant that does not receive light they grew faster than the part that receives light. So the stem bends towards the direction of light.

36. If  $u$  is the distance of object and  $v$ , the distance of image from optical centre of the lens, then focal length  $f$  is related to  $u$  and  $v$  by  $\frac{1}{f} = \frac{1}{v} - \frac{1}{u}$  which is called lens formula. The formula is equally applicable to convex, concave or any other type of lens. (e.g. concavo-convex, plano-convex, convexo-concave, plano-concave etc.)

**Sign Conventions:**

- (1) The object is always placed to the left of the lens.
- (2) All distances parallel to principal axis are measured from optical centre of the lens.
- (3) All distance measured to the right of optical centre (along x-axis) are taken as positive while those measured to the left of optical centre (along x-axis) are taken as negative.
- (4) Distance measured perpendicular to and above the principal axis (along y axis) are taken as positive.
- (5) Distance measure perpendicular to and below the principal axis (y'-axis) are taken as negative.

**Assumptions** (1) Object is taken on principal axis. (2) The lens is thin.

OR

Concave Mirror	Convex Mirror
A concave mirror is made by silvering the outer surface of a part of a hollow sphere and reflection takes place from the inner surface.	A convex mirror is made by silvering the inner surface of a part of a hollow sphere and reflection takes place from the outer bulging surface.
Concave mirrors are converging mirrors. The light rays incident on a concave mirror converges after reflection.	A convex mirror is a diverging mirror. The light rays incident on a convex mirror diverges after reflection.
The image formed by it is real as well as virtual depending on the position of the object from the mirror.	The image formed by it is always virtual for all positions of the object in front of the mirror.

**Section E**

37. Read the text carefully and answer the questions:

The teacher while conducting practicals in the laboratory divided the students into three groups and gave them various solutions to find out their pH and classify them into acidic, basic and neutral solutions.

Group A - Lemon juice, vinegar, colourless aerated drink

Group B - Tomato juice, coffee, ginger juice

Group C - Sodium hydroxide, sodium chloride, lime water

- (i) i. Groups A and B - less than 7
- ii. Group C - greater than 7

(ii) pH paper and universal indicator.

OR

- i. Copper vessel is tarnished due to formation of basic copper oxide.
- ii. Lemon juice being acidic react with copper oxide and the salt formed is washed away.

38. Read the text carefully and answer the questions:

Fill a conical flask with water. Cover the neck of the flask with a wire mesh. keep two or three freshly germinated bean seeds on the wire mesh. Take a cardboard box which is open from one side. Keep the flask a wire mesh. Kin the box in such a manner that the open side of the box faces light coming from a window as shown in the given figure. After two or three days, you will notice that the shoots bend towards light and roots away from light. Now turn the flask so that the shoots are away from light and the roots towards the light. Leave it undisturbed in this condition for a few days. Plants show tropism in response to other stimuli as well. The roots of a plant always grow downwards while the shoots usually grow upwards and away from the earth. This upward and downward growth of shoots and roots, respectively, in response to the pull of earth or gravity, is obviously, geotropism.



- (i) These activities show tropic movements in plants due to their growth.
- (ii) Yes, old parts of the shoot and root change direction and there is a difference in the direction of new growth.
- (iii) Movement is related to stimulus i.e. plant organs either move towards the source of stimulus or away from it. Stimuli that cause movements in plants are gravity, light, touch, water, and chemical substances.

OR

Movements in the organs of a plant due to gravity are known as geotropism. This causes the roots to bend down towards the soil.

**39. Read the text carefully and answer the questions:**

A student was asked to perform an experiment to study the force on a current carrying conductor in a magnetic field. He took a small aluminum rod AB, a strong horse shoe magnet, some connecting wires, a battery and a switch and connected them as shown. He observed that on passing current, the rod gets displaced. On reversing the direction of current, the direction of displacement also gets reversed. On the basis of your understanding of this phenomenon, answer the following questions :

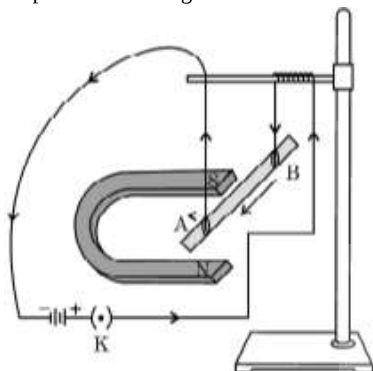

- (i) The displacement of the conductor is maximum when the direction of the current is at right angles to the direction of the magnetic field.
- (ii) The rule that determines the direction of the force on the conductor AB is Fleming's left-hand rule.  
According to Fleming's left-hand rule, stretch the thumb, forefinger and middle finger of your left hand such that they are mutually perpendicular.  
If the first finger points in the direction of the magnetic field and the second finger in the direction of current, then the thumb will point in the direction of motion or force.
- (iii) i. According to Fleming's left-hand rule, the rod will get displaced upwards.  
ii. Devices that use current-carrying conductors and magnetic fields are electric motors, electric generators, loudspeakers, microphones, etc.

OR

